



## 1 & 2 PC FULL BORE BALL VALVES

### FUSION SERIES

#### MODELS

T23 Full Port (2PC)  
S23 Seal Weld (1PC)

#### SIZE Range 1/4 thru 4"

1/4 - 2" 2000 WOG  
2 1/2 - 4" 1500 WOG

STEAM T23 - 150 SWP  
S23 - 250 SWP

API 607-5 CERTIFIED  
API 608  
NACE MR-01-75

#### THREADED ENDS

ANSI B1-20-1 NPT  
Shell Wall ANSI-B16.34  
Testing to 3000 PSI

ANTI-STATIC GROUND

LOCKING HANDLE

OVAL HANDLE

TRACEABILITY

FOUNDRY HEAT # FOR ALL VALVES

METAL NAME PLATES IDENTIFYS ALL  
SOFT PARTS

#### VALVE BREAK TORQUES

SIZE	T23 TORQUE	S23 TORQUE	WEIGHT LBS	C <sub>v</sub>
1/2	60	85	.97	15
3/4	80	112	1.35	38
1	95	130	2.25	65
1 1/4	190	265	3.20	118
1 1/2	318	440	5.20	195
2	385	530	8.65	320
2 1/2	480	670	14.77	410
3	800	1100	21.60	640
4	1700	2300	44.75	1660



1" - T23



2" - S23

#### Seal Weld Design Model S23

Eliminating the possibility of body tail piece unthreading  
Eliminating any possible leakage at body joints - safe, sure pressure containment.

Automatic Welding equipment is used for welding body joints. The welding width is always uniform and the weld penetration is consistent. Our equipment maintains a consistence water flow inside the valve, this assures a safe temperature which prevents damage to all valve seats and seals.

**DESIGN & TECHNICAL DATA**

**FUSION SERIES**

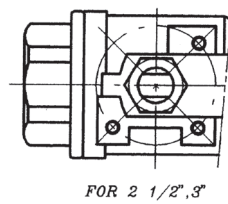
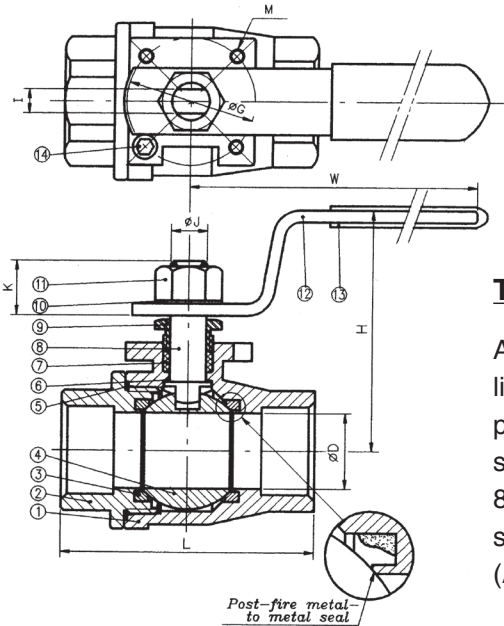

**TESTING**

All valves are factory tested as listed below in open and closed position for bubble tight integrity seat: air under water at 80-100 PSI (MSS-SP-72)  
shell: Hydrostatic @ 3000 PSI (ANSI-B16.34)

**MODELS**

T23 Full Port 2 PC  
S23 Full Port Seal Weld 1 PC

**PRESSURE RATINGS**

1/4 - 2" 2000 WOG  
2 1/2 - 4" 1500 WOG

**STEAM WORKING PRESSURE**

T23 - 150 SWP S23 - 250 SWP

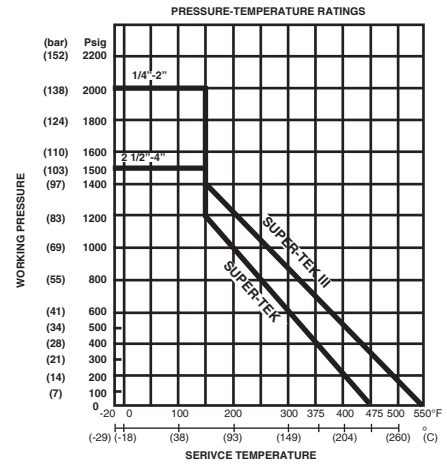

*All Valves Are Fire Safe Certified to API 607-5  
All Valves Comply With API 608*

**DIMENSIONS**

SIZE		ØD		L		I		ØJ		K		ØG		H		W		M
in	mm	in	mm	in	mm	in	mm	in	mm	in	mm	in	mm	in	mm	in	mm	
1/4"	8	0.43	11	2.32	59	0.20	5	0.31	8	0.35	9	1.42	36	2.17	55	5.31	135	M5
3/8"	10	0.49	12.5	2.32	59	0.20	5	0.31	8	0.35	9	1.42	36	2.17	55	5.31	135	M5
1/2"	15	0.59	15	2.54	64.5	0.20	5	0.31	8	0.45	11.5	1.42	36	2.24	57	5.31	135	M5
3/4"	20	0.79	20	2.87	73	0.24	6	0.39	10	0.59	15	1.42	36	2.46	62.5	5.31	135	M5
1"	25	1.00	25.4	3.37	85.5	0.31	8	0.47	12	0.63	16	1.65	42	2.70	68.5	6.50	165	M5
1 1/4"	32	1.26	32	3.94	100	0.31	8	0.47	12	0.71	18	1.65	42	2.91	74	6.50	165	M5
1 1/2"	40	1.50	38	4.53	115	0.31	8	0.55	14	0.79	20	1.97	50	3.56	90.5	6.89	175	M6
2"	50	1.97	50	5.28	134	0.31	8	0.55	14	0.79	20	1.97	50	3.92	99.5	6.89	175	M6
2 1/2"	65	2.56	65	6.54	166	0.47	12	0.79	20	1.14	29	2.76	70	5.06	128.5	9.57	243	M8
3"	80	3.15	80	7.44	189	0.47	12	0.79	20	1.14	29	2.76	70	5.49	139.5	9.57	243	M8
4"	100	3.94	100	9.09	231	0.63	16	0.98	25	1.22	31	4.02	102	6.59	167.5	10.79	274	M10

Flo-Tite reserve the rights to modify our product design or construction for improvement without prior notice.

**MATERIALS LIST**

NO.	PARTS	S-23 SS	S-23 CS
1	BODY	ASTM A351-CF8M	ASTM A216-WCB
2	END CAP	ASTM A351-CF8M	ASTM A216-WCB
3	SEAT	SUPER-TEK III	25% CARBON TFM
4	BALL	ASTM A351-CF8M/316	ASTM A351-CF8/304
5	GASKET	GRAPHITE	GRAPHITE
6	THRUST WASHER	GRAPHITE	GRAPHITE
7	STEM PACKING	GRAPHITE	GRAPHITE
8	STEM	ASTM A276-316	ASTM A276-304
9	GLAND	AISI 304	AISI 304
10	HANDLE WASHER	AISI 304	AISI 304
11	HANDLE NUT	AISI 304	AISI 304
12	HANDLE	AISI 304	ZINC PLATED STEEL
13	HANDLE COVER	PVC	PVC
14	STOP SCREW	AISI 304	CARBON STEEL

**MATERIALS LIST**

NO.	PARTS	T-23 SS	T-23 CS
1	BODY	ASTM A351-CF8M	ASTM A216-WCB
2	END CAP	ASTM A351-CF8M	ASTM A216-WCB
3	SEAT	SUPER-TEK	TFM 1600
4	BALL	ASTM A351-CF8M/316	ASTM A351-CF8/304
5	GASKET	GRAPHITE	GRAPHITE
6	THRUST WASHER		
7	STEM PACKING	GRAPHITE	GRAPHITE
8	STEM	ASTM A276-316	ASTM A276-304
9	GLAND	AISI 304	AISI 304
10	HANDLE WASHER	AISI 304	AISI 304
11	HANDLE NUT	AISI 304	AISI 304
12	HANDLE	AISI 304	ZINC PLATED STEEL
13	HANDLE COVER	PVC	PVC
14	STOP SCREW	AISI 304	CARBON STEEL